

ERG CONTAINER LOADING & UNLOADING CONVEYOR

《Operation and Maintenance Manual》



Ningbo Ergate Intelligent Technology Co., Ltd

1st July of 2024

DIRECTORY

1. Warning.....	1
2. Note.....	3
3. Conveyor Overview.....	6
4. Type & main technical parameter	6
5. Lifting and Handling.....	8
6. Installation and Adjustment.....	9
7. Schematic Description of Button Layout.....	11
8. Preparation before startup.....	14
9. Operating instructions.....	15
10. Maintenance and upkeep.....	16
11. Fault analysis and troubleshooting.....	19
12. Appendix.....	22

Dear customer, you are highly appreciated for purchasing our company's ERG container loading and unloading conveyor. In order to ensure proper use of this equipment, carefully read this operation and maintenance manual after receiving it please.

The manual provides a detailed description of lifting, installation, operating methods as well as precautions in use. Improper use may result in unexpected malfunctions or even serious consequences. To ensure the safety of operators, the equipment and other property, please read this manual carefully before using it. Do not operate it unless have a clear idea of its functions, performance, technical parameters and the methods. Follow this manual in later installation, moving, debugging and maintenance process. Improper use will result in abnormal operation, short service life and malfunctions. Please keep this manual after use.

Must read this manual and other auxiliary materials thoroughly in order to use them correctly before installation, operation, maintenance and check of this equipment. Following matters may result in personal injury or serious equipment damage, please check them strictly before use.

1. **! Warning !**

1.1 Danger

The warning is to draw your attention to the danger, which may result in serious injury or death. If appropriate preventive measures are not taken, accidents will definitely happen.

During the operation or movement of ERG loading and unloading conveyor, it is forbidden to cross over it, otherwise injury or death will happen. When the ERG Container loading and unloading conveyor is travelling outside the container, it is suggested to steer it by Remote Controller, other than standing on it and steering it by switches on the panel, to avoid danger of falling down or collision.

1.2 Warning

The warning is to alert you to the danger, otherwise it may result in injury or death. If preventive measures are not taken appropriately, accidents may happen.

1.2.1 The ERG container loading and unloading conveyor cannot be started, until it send out a self-check signal before operation.

1.2.2 The ERG container loading and unloading conveyor is driven by an electric motor. When carrying out any maintenance work, make sure that the power supply has been cut off. The so-called 'cut off' means that maintenance personnel hangs out tags, lock them out, and remove cables from the power supply outlet or other similar devices. Any other understanding is inaccurate, or it will result in injury and equipment damage.

1.3 Watch out

The warning is to alert you to the danger, otherwise it may result in injury or equipment damage. This type of danger is not serious usually, but the consequences of its development are terrifying. If preventive measures are not taken appropriately, fatal injury may even happen.

Make sure that there are no flammable or explosive materials on the reducer, coupling cover and motor, otherwise it may result in a fire due to the equipment overheating.

1.4 Safety knowledge

1.4.1 Keep a certain distance from all moving components and machines, and loose clothing (especially at the collar, cuffs, trouser legs, etc.) is forbidden during operation check of the ERG container loading and unloading conveyor.

1.4.2 The ERG container loading and unloading conveyor can not be started until it is

confirmed that all components have been correctly installed after check.

1.4.3 Make sure that all bolts and fasteners are in right place and tightened correctly.

2.Note

2.1 Avoid electricity shock

2.1.1 When the equipment is in operation, do not open the cabinet or the junction box cover, otherwise electricity shock may happen.

2.1.2 Before power-off maintenance, make sure that the indicator of electrical cabinet is off, and confirm it by a universal meter.

2.1.3 Grounding work should be taken between various parts of the equipment.

2.1.4 Do not operate the equipment with wet hands to avoid electricity shock.

2.1.5 Do not damage the cables. Applying excessive stress to the cables can result in short circuits, electricity shock, etc.

2.2 Fire prevention

2.2.1 Install the equipment away from flammable and explosive materials or equipment, otherwise fire will happen.

2.2.2 The connecting cables between the equipment and the outer should be strictly selected according to the regulations in this manual and connected firmly, otherwise it may become the cause of fire.

2.2.3 When installing this equipment, do not block the forced ventilation outlet, otherwise it may become the cause of fire.

2.3 Prevention of damage

2.3.1 Do not apply voltage beyond the stipulation in the manual to each terminal, otherwise it may become the cause of equipment burst or damage.

2.3.2 Do not mistake the connection of the terminals, otherwise it may become the cause of equipment burst and damage.

2.3.3 After long-term discard of the equipment (more than 1 year), it must be checked and confirmed by professional personnel before use, otherwise it may become the cause of equipment burst and damage.

2.3.4 After the equipment is damped, it must be dried sufficiently and checked by professional personnel before use, otherwise it may become the cause of equipment burst and damage.

2.3.5 After long-distance transportation or accidents such as fall or collision, the equipment must be checked to confirm that there are no phenomenon of component detachment or damage before use, otherwise it may become the cause of equipment burst or damage.

2.3.6 Reliable lightning protection and grounding measures should be taken to the control cabinet, otherwise it may become the cause of equipment burst and damage.

2.3.7 In non-debugging state, it is not allowed to cover various testing switches artificially, otherwise injury and equipment damage may happen.

2.4 Other notes

Pay attention to the following precautions sufficiently. Improper use may occasionally result in unexpected malfunctions, injury and electricity shock.

2.4.1 Adopt correct lifting and transporting tools during transportation and installation. Do not have the equipment fall or collide strongly.

2.4.2 Do not put heavy objects and other debris onto the equipment.

2.4.3 The installation direction must be strictly followed.

2.4.4 It is strictly prohibited to have other alien conductive objects such as screws and metal sheets, or

combustible objects such as oil inside the control cabinet of frequency converter.

2.4.5 The debugging and maintenance work should be carried out by professional technical personnel.

2.4.6 Do not modify the equipment.

2.4.7 If the equipment is to shut down for a long time, turn off main power supply of the equipment.

2.4.8 The location of electrical cabinet must comply with relevant fire regulations, reserve passage for operation without obstacles.

2.4.9 The transported items should be placed gently onto the middle of belt.

2.4.10 It is prohibited to strike the equipment by hard objects.

2.4.11 It is prohibited to scratch the belt with a blade or sharp objects.

2.4.12 During operation, if any abnormal noise or stuck sound is detected in the equipment, it should be immediately stopped for check. It is permitted to restart it only after troubleshooting.

2.4.13 During maintenance, make sure power supply is cut off, and a warning tag is in position to alert.

2.4.14 It is forbidden to cross or pass through the equipment.

2.4.15 It is forbidden to sit, lie, or walk on the belt.

2.4.16 It is forbidden to clean debris on the belt during operation.

2.4.17 It is forbidden to carry out daily operation and maintenance by non-professional personnel.

2.4.18 It is forbidden to touch the moving parts of the equipment, such as belt or rollers by hands or other parts of the body.

2.4.19 It is forbidden to touch the movable gap or moving parts of the rack by hands or other parts of the body.

3. Structure and basic function

The ERG container loading and unloading conveyor is mainly used in cross-border e-commerce overseas warehouses with a huge number of SKU, for unloading and loading containers with various outer packages (cardboard boxes, plastic bags, etc.), various shapes and sizes (long, square, round, flat), and irregular parcels no more than 50KGS. It replaces traditional telescopic conveyors for efficient, safe, labor-saving and low-cost loading and unloading.

3.1 The ERG container loading and unloading conveyor adopts a large number of ergonomic principles in its design, which enables the operating platform and unloading belt conveyor to sway left and right, allowing the operator to adjust the position to any height and width in the container at his own will, and drag the goods onto the belt conveyor with minimum force and the shortest distance (instead of lifting and putting them strenuously), achieving labor-saving, efficiency and safety.

3.2 The ERG container loading and unloading conveyor adopts AGV steering technology and battery power supply, which enables it to use its own power to move among the warehouses and climb vehicle loading ramp, solving the problem of moving difficulty of traditional telescopic conveyor due to its huge size and weight. It can achieve multi functions and one equipment for multiple docks, reducing the overall investment of equipment.

3.3 The ERG container loading and unloading conveyor can realize bidirectional transportation for loading and unloading materials according to customers' requirement.

4. Type and main technical parameters (if belt is mentioned in this manual, it means the conveying medium is belt; Otherwise the medium is chain plate.)

4.1 The ERG container loading and unloading conveyor is composed of ① AGV self-driven steering and control system; ② servo-controlling platform lifting system; ③ Steering and lifting mechanism of loading and unloading conveyor part; ④ Main control cabinet and front operation panel control system; ⑤ Flexible roller conveyor (Optional) ; ⑥ warning and reminder signs, safety devices and infrared sensors, shown in Figure 1

Figure 1



4.2 Main technical parameters:

4.2.1 Conveying capacity: $\leq 50\text{KGS/PC}$

4.2.2 Conveying speed: 15-35m/min

4.2.3 Transmission power: $0.55\text{kW} * 3$

4.2.4 Lifting power: 0.55kW

4.2.5 Walking speed: two modes adjustable

4.2.6 Belt deviation: $\leq 20\text{mm}$

4.2.7 Transmission: optional for bidirectional loading and unloading

4.2.8 Operation mode: front operation panel, main control cabinet, and remote control device

4.2.9 Input voltage: according to local voltage

4.2.10 Overall weight: 1300-1800KGS

4.2.11 Overall size: L3000 * W1850 * H2200MM

5. Lifting and Handling

5.1 Equipment lift

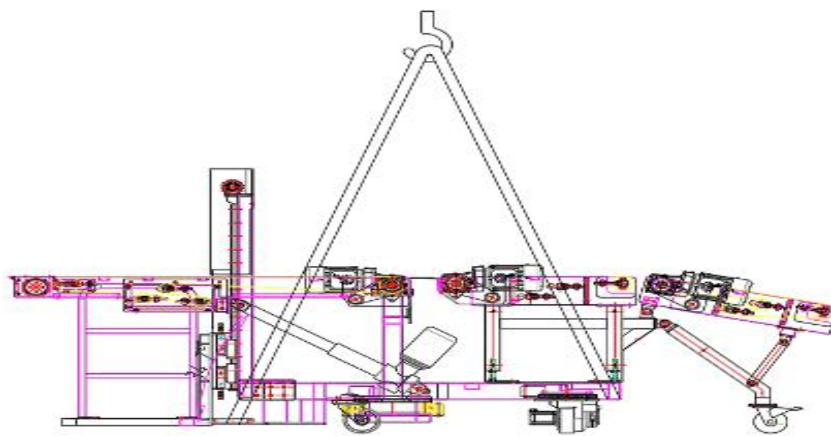

5.2 forklift transportation

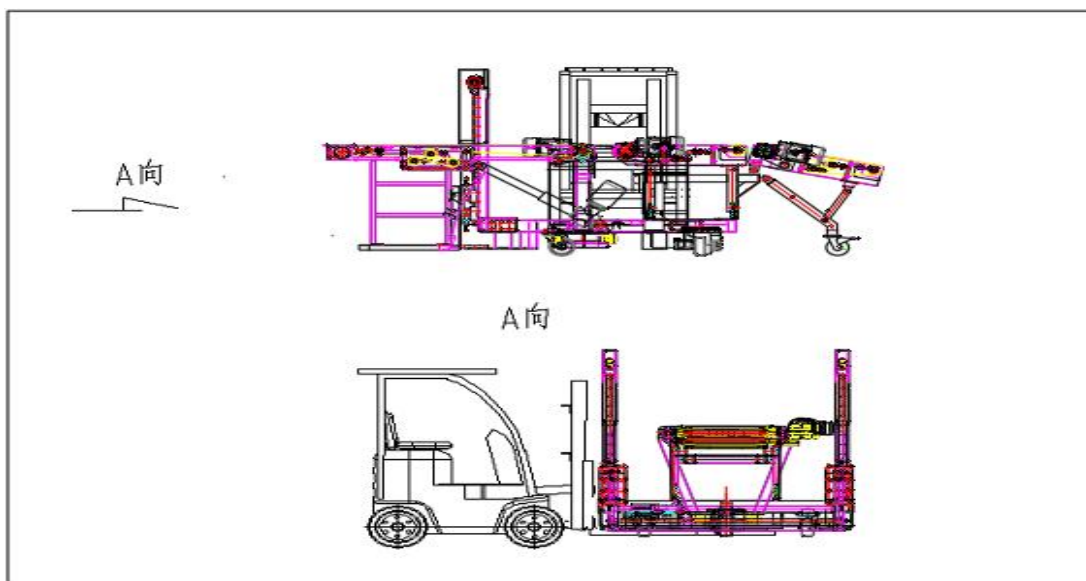

5.3 Precautions for lifting and handling:

When handling equipment, nylon straps should be placed according to the position shown in the picture (lifting capacity more than 3 tons). Before lifting and handling, the equipment should be retracted back to its starting status. During lifting and handling, do not bump the button box or electric control cabinet, avoid the AGV steering wheel and servo lifting device on the base. At the same time, be careful not to have the lifting equipment press parts such as wires and oil pipes. Before lifting the equipment, soft substances should be used to contacting points to protect surface paint. During lifting and handling, it should be steady to avoid collision and vibration to damage the equipment.

6. Check and adjustment before use

6.1 Check

The ERG container loading and unloading conveyor is a complete set of equipment, so its belt, telescopic performance of the movable rack and various mechanisms on the base are adjusted before leaving the factory. However, due to long-distance transportation, a comprehensive check and debugging of the ERG container loading and unloading conveyor should be carried out by professional personnel before use. It is permitted to take delivery for use after performance and indicators have met the usage requirement.

6.2 Adjustment

6.2.1 Idle operation

6.2.1.1 Before trial operation, tighten the conveyor belt to apply sufficient tension to ensure that the belt does not slip on the rollers during startup and transmission. (Our company has already adjusted it before leaving the factory)

6.2.1.2 During operation, if slipping, deviation or other abnormal phenomenon happen, it should be immediately stopped for adjustment.

6.2.1.3 When installing or debugging the ERG loading and unloading conveyor or during operation, if the conveyor belt deviates, the reason for deviation should be determined based on its operating and deviation direction. The supporting rollers and each directional roller should be adjusted separately. This adjustment does not have an immediate effect usually and should be

observed for a period of time before making a judgment. If the conveyor belt deviates to the other side after adjustment, adjust the supporting rollers subtly again, which are adjusted just before.

6.2.1.4 When the conveyor belt deviates at the rollers, adjust the rollers at the side the belt deviates to. The method is to adjust the position of the rollers by the adjusting bolts at the roller bearings.

6.2.2 Adjust the operating tension of the conveyor belt

The required tension is based on the conveying volume and distance. When the ERG loading and unloading conveyor is working normally, its initial tension must make sure of no slipping. The initial tension changes with the differences of conveying volume and distance. Excessive tension can lead to early damage to the conveyor belt, while less tension can result in slipping. Therefore, it is required to adjust the initial tension of the conveyor belt. The adjustment is well-done when the belt does not slip on the conveying rollers.

6.2.3 The issues to be noted during trial operation

Firstly, the idle operation is set to be no less than 2 hours. Observe, check and adjust each part to prepare for the loading or unloading operation.

6.2.3.1 Observation and adjustment during idle operation: During the idle operation, it is required to carefully observe the operation of each part of the equipment and adjust them at once if any problems are found.

6.2.3.2 Whether there is any rubbing phenomenon between each operating component (usually there will be abnormal noise when interference happens), especially when it rubs against the conveyor belt, it is required to be solved immediately to prevent damage to the conveyor belt.

6.2.3.3 Whether the conveyor belt deviates, if yes, it is required to adjust it.

6.2.3.4 Whether abnormal sounds and vibration happens to each part of the equipment.

6.2.3.5 Whether oil leakage happens to the reducer or other lubricated parts.

6.2.3.6 Whether the temperature of lubricating oil and bearing is normal.

6.2.3.7 Whether the tension device operates well and whether it jams.

6.2.3.8 Whether the connecting bolts of the base as well as other parts are loose.

7. Diagram of button operation (Following diagram is for reference only, actual design will prevail.)

7.1 Layout diagram of main control cabinet

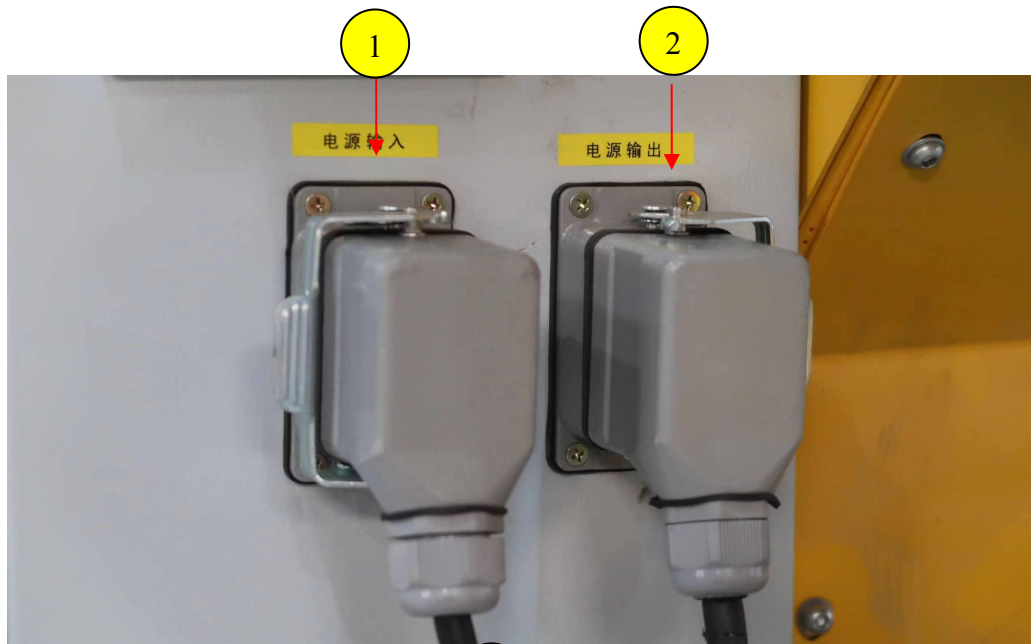

7.2 AGV steering wheel control cabinet



7.3 Front operation control panel

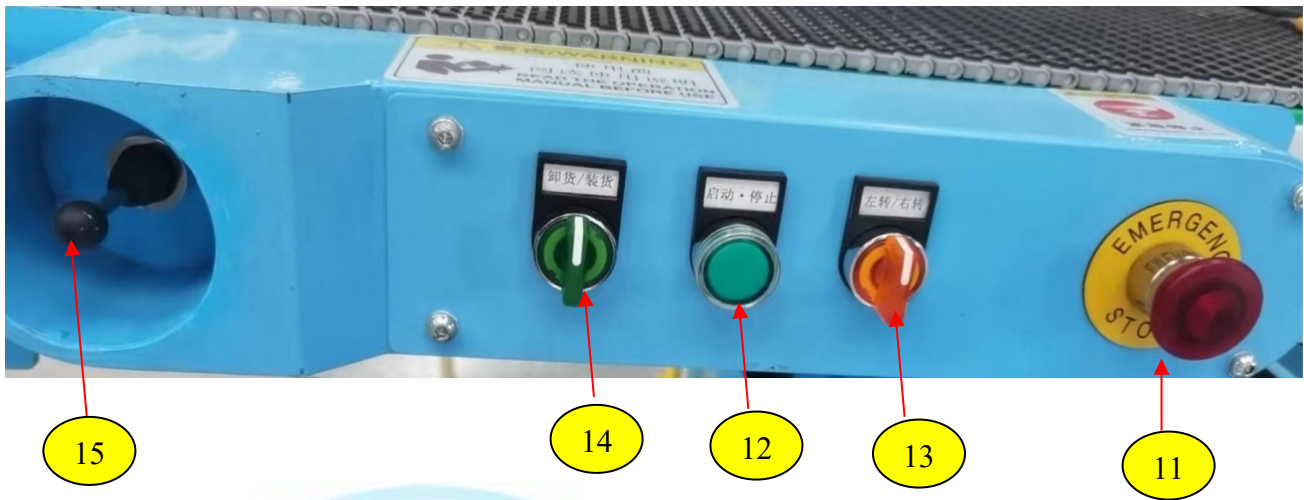

- 1: Power inlet of Main control cabinet .
2. Power outlet of Main control cabinet for Motorized Flexible Roller Conveyor.
3. Fault indicator of Main control cabinet, it will light up when breakdown happens.
4. Beep alarm: When breakdown happens, it will alarm at a certain time rhythm.
5. Isolating switch of Main control cabinet: Turn on the power by rotating the switch at 90 degrees before starting the equipment; Otherwise turn off;
6. Fault indicator of The AGV control cabinet, it will light up when breakdown happens to AGV.
7. Isolating switch of AGV control cabinet : Turn on the power by rotating the switch at 90 degrees before starting the equipment.
8. AGV steering wheel charging socket.
9. AGV steering wheel charging indicator.
10. AGV beep alarm: if there's something wrong with the AGV, it will alarm at a certain time rhythm.
11. Emergency button: Press the button in any emergency, and rotate it to release when the emergency is dissolved.
12. Start and stop button: for the function of conveying, lighting, .
13. Turning switch: turn left or right.
14. Loading or unloading switch.

15. Master switch: if you switch the lever up and down, the operating platform and the unloading conveyor will get up and down simultaneously; if you switch the lever forward or backward, the AGV steering wheel will move accordingly.

8.Preparation before startup

8.1 Check the voltage of power supply is suitable for the motors.

8.2 The control power supply is DC 24V.

8.3 Confirm that there is no unsafe condition (for equipment and body) on the ERG container loading and unloading conveyor.

8.4 Confirm that the emergency button on the control cabinet and operation panel is in the out position, and there is no fault alarm. Only after check and confirm it, following operation can be carried out.

8.5 Connect the power supply by inlet and outlet of the main control cabinet, and the white indicator will light up on the cabinet.

8.6 Turn the isolating switch on the left side of the main control cabinet to ON position, and the main power supply is connected.

8.7 Turn the isolating switch on the right side of the AGV steering wheel control cabinet to the ON position, and power supply is connected;

8.8 Check the AGV steering wheel charging indicator. If the power amount is less than 50%, turn on the charging switch for charging.

Note: above operation is set for the first operation of the equipment.

After that, to start the equipment, simply rotate the QS0 conversion switch of the main control cabinet to the ON position to connect the main power supply; To shut it down, simply rotate the QS0 conversion switch of the main control cabinet to the OFF position to turn off the main power supply.

9. Operating instructions

9.1 Select the belt moving direction: Press the loading button on the front operation panel, and the belt will move in the forward direction; Press the unloading button on the front operation panel, and the belt will move in reverse. Front belt conveyor upward and downward operation: Switch the lever of master switch upward (the operation platform rises simultaneously), the middle relay is closed, and the belt conveyor swings upward. Released the lever, the belt conveyor stops swinging upward; When the belt conveyor swings upward to the limit stroke switch or magnetic switch, the belt conveyor stops swinging up. Switch the lever of master switch downward (the operation platform descends simultaneously), the middle relay is closed, and the belt conveyor swings downward. Release the lever, and the belt conveyor stops swinging downward; When the belt conveyor swings downward to the limit stroke switch or magnetic switch, the belt conveyor stops swinging down.

9.2 Operation platform lifting and descending: Rotate the switch for separate lifting of the operating platform on the front operation panel to lifting position, or switch the lever of master switch upward, the middle relay is closed. The operation platform of ERG container loading and unloading conveyor rises. When the operation platform rises to the limit stroke switch or magnetic switch, it stops rising; Rotate the switch for separate lifting of the operation platform on the front operation panel to descending position, or switch the lever of master switch downward, The middle relay is closed. The operation platform of ERG container loading and unloading conveyor descends. When the operation platform descends to the limit stroke switch or magnetic switch, it stops descending.

9.3 Automated movement: When carrying out loading and unloading operation inside the container, the ERG container loading and unloading conveyor can move forward or backward by switching the lever of master switch forward or backward. If turning right or left is in need, it is required to stand outside the equipment and realize it by remote control device.

9.4 Emergency stop: When the operation of the belt conveyor poses a threat to human body or equipment, press the emergency button on the control cabinet or operation panel to immediately stop the operation of the belt conveyor. When the motor is overloaded or short-circuited, the circuit breaks or the frequency converter performs protection function, the faulty contact acts, stop the operation of belt conveyor; Beep alarm alerts, identify the cause of overload or short circuit firstly, start the belt conveyor again after troubleshooting.

10. Maintenance

The ERG container loading and unloading conveyor and its main parts should be well maintained according to regulations. The moving parts and driving devices should be regularly checked, adjusted, maintained and cleaned. The maintenance should be carried out only after the equipment is stationary and the driving devices are all turned off.

10.1 Maintenance and Repair

10.1.1 Normally, it is required to have idle operation start for the ERG container loading and unloading conveyor and avoid short-term start.

10.1.2 It is required to check the reducing motor regularly for oil leakage, and supplement the oil in a reasonable and timely manner.

10.1.3 A scream at the rollers indicates the conveyor belt is slipping, and it is required to checked tension of belt.

10.1.4 It is required to check and adjust the deviation of the conveyor belt regularly.

10.1.5 All protective devices for the ERG container loading and unloading conveyor must be kept complete, and a dedicated person must be assigned to regularly check and verify them to ensure the reliability of operation.

10.1.6 The check and adjustment of the ERG container loading and unloading conveyor in use should be carried out with protective devices, unless the described operation cannot be carried out if the protective devices are removed. If certain protective devices have to be removed, it is required to take necessary preventive measures, and it is forbidden to approach the parts with bite risk.

10.1.7 If the area where the protective devices is to be removed is located in the workspace or passage, it is required to surround these areas from approaching during operation.

10.1.8 Before repairing the protective devices, make sure the ERG container loading and unloading conveyor is shut down, and the driving device cannot be started. Make sure protective devices are installed before restarting. If repair has to be carried out on unprotected equipment in operation, there must be a guardian to guard the personnel at work. The guardian should be familiar with the measures to be taken in each situation and should be close to the emergency button to stop the equipment at any time.

10.2 Check and maintenance period

10.2.1 Daily check

10.2.1.1 Whether the conveyor belt of whole equipment operates normally, and whether there is any abnormal phenomenon such as grinding, deviation, etc.

10.2.1.2 Whether the temperature of reducer, motor and all roller bearings is normal.

10.2.1.3 Whether there is any oil leakage in the reducer.

10.2.1.4 Check all the oil seals and bearings of rollers, whether there is heat or abnormal noise.

10.2.2 Weekly check

Besides daily checks, additional one is to check the oil level of the reducing motor. If necessary, add the specified oil.

10.2.3 Monthly check

In addition to the daily and weekly checks, the following additional items are required for monthly check:

10.2.3.1 Check the wear and tear of all oil seals and bearings of rollers.

10.2.3.2 Add oil to all roller bearings and clean the dirt on the rollers.

10.2.3.3 Clean the reducing motor, replace the lubricating oil, and analyze oil replacement period.

10.2.3.4 Check the wear and tear of all oil seals and bearings.

10.2.3.5 Check the service life of the battery, and replace it timely if its charging is abnormal.

For lubrication of other parts, refer to the following table please:

NO.	Position	Lubrication method	Brand	Standard	Oil change period
1	Reducing Motor	oil bath	LCKC220	GB5903-1995	12month
2	Driving roller bearing	Pressure injection	2 # lithium grease	GB7323-94	Half a month
3	Active telescopic bearing	Pressure injection	2 # lithium grease	GB7323-94	Half a month

11. Fault analysis and troubleshooting

Common faults and troubleshooting below:

NO	Common faults	Common faults analyze	processing method
1	The motor cannot start or immediately slows down after start	<ol style="list-style-type: none"> 1. circuit failure 2. voltage drop 3. Contactor failure 4. Continuous start within 1.5 seconds 	<ol style="list-style-type: none"> 1. check the circuit 2. Check voltage 3. Check overload electrical appliances 4. Reduce the number of operations
2	motor overheating	<ol style="list-style-type: none"> 1. Overload, over-length, or belt being jammed increases the operation resistance and the motor is overloaded. 2. Due to poor lubrication of the transmission system, the power of motor increases. 3. Dust accumulation in the fan inlet or radial heat sink of the motor worsens radiating condition. 	<ol style="list-style-type: none"> 1. Measure the power of motor, identify the cause of overload and take corresponding measures. 2. Supplement lubricating oil for each transmission part timely. 3. clear dust.
3	Reducer overheating	<ol style="list-style-type: none"> 1. Too much or little oil in the reducer. 2. Lubricating oil has been used for a much long time. 3. Bearings damaged due to poor lubrication. 	<ol style="list-style-type: none"> 1. Inject oil according to the specified amount. 2. Clean the interior of reducer, replace oil or bearings timely, and improve lubrication condition.
4	Belt deviation	<ol style="list-style-type: none"> 1. The rack and rollers are not adjusted straightly. 2. The axis of rollers is not perpendicular to the center line of conveying belt. 	<ol style="list-style-type: none"> 1. Adjust the rack or roller to ensure they are flat and straight. 2. Correct the deviation of conveying belt by adjusting the supporting rollers.

5	Aging and tearing of conveying belt	<ol style="list-style-type: none"> 1. Friction between the conveying belt and the rack results in rough edge and cracks. 2. The conveying belt is torn due to interference with hard fixed objects. 3. Poor preservation 4. excessive tension 	<ol style="list-style-type: none"> 1. Adjust the rollers timely to avoid long-term deviation of the conveying belt. 2. Prevent the conveying belt from hanging onto fixed components or falling metal structures into the conveying belt. 3. Prevent the conveying belt from rain, the sun, fire and rude operation.
6	belt break	<ol style="list-style-type: none"> 1. The material of the belt is not suitable, so it becomes hard and brittle when exposed to water or cold. 2. Long-term use of conveying belts results in strength decrease. 3. The joint quality of the conveying belt is poor, and local cracks are not repaired timely. 	<ol style="list-style-type: none"> 1. Produce high-quality belt cores by materials with stable mechanical and physical properties. 2. Replace damaged or aged conveying belts timely. 3. Check the joints regularly and solve any problems found timely.
7	belt slipping	<ol style="list-style-type: none"> 1. Insufficient tension of conveying belt and overload. 2. Due to certain liquid, the friction coefficient between the rollers and the conveying belt decreases. 	<ol style="list-style-type: none"> 1. Readjust the tension or reduce the loading quantity. 2. Avoid liquid splash and increase tension
8	The power indicator is off	<ol style="list-style-type: none"> 1. The power supply is not connected. 2. Circuit breaker QF01 is disconnected. 3. Switch tripped, short circuited. 4. Indicator HL01 is damaged. 	<ol style="list-style-type: none"> 1. Connect the power supply. 2. Connect circuit breaker QF01. 3. Check the circuit and close the switch. 4. Replace the indicator.
9	Fault indicator is on always.	<ol style="list-style-type: none"> 1. The emergency button is pressed down. 2. The emergency contact is damaged. 	<ol style="list-style-type: none"> 1. Recover the emergency button. 2. Replace the emergency contact.

10	Operation platform cannot get up/down	<ol style="list-style-type: none"> 1. Limit switch acts. 2. Emergency button pressed down. 3. Motor overloaded, switch tripped. 	<ol style="list-style-type: none"> 1. Operate in the opposite direction. 2. Recover the emergency button.
11	Press the start button, the conveyor does not work	<ol style="list-style-type: none"> 1. The protection current of the frequency converter is set too low. 2. Emergency button pressed down. 3. Motor overloaded, switch tripped. 	<ol style="list-style-type: none"> 1. Set the appropriate current value according to the load. 2. Recover the emergency button.
12	Belt conveyor does not get up/down	<ol style="list-style-type: none"> 1. Limit switch acts. 2. Emergency button pressed down. 3. Motor overloaded, switch tripped. 	<ol style="list-style-type: none"> 1. Operate in the opposite direction. 2. Recover the emergency button.
13	<p>Beep alarm and fault indicator works continuously, overload reported: breakdown</p> <p>Intermittently: Indication of getting up/down of the belt conveyor or operation platform.</p>	<ol style="list-style-type: none"> 1. The overload current value of the frequency converter is set too low. 2. Emergency stop fault. 3. Motor overloaded. 4. The insulation impedance of the motor decreases, the impedance of the three-phase winding is unbalanced, and the motor is damaged. 	<ol style="list-style-type: none"> 1. Set the current value of the frequency converter according to the nameplate. 2. Recover the emergency button or replace the button contact. 3. Check for mechanical jamming and eliminate it. 4. Test the insulation impedance of the motor, check if the impedance of the three-phase winding is balanced, and replace the motor.
14	AGV steering wheel does not work.	<ol style="list-style-type: none"> 1. AGV main cabinet not powered on. 2. Remote control device short of power. 3. The remote control device has low battery and needs to be charged. 	<ol style="list-style-type: none"> 1. Power on the main electrical cabinet. 2. Replace the built-in battery of the remote control device. 3. Charge the remote control device or replace the battery.

12. Appendix

12.1 Electrical diagram required for maintenance level and manual for frequency inverter

12.2 List of special tools and spare parts along with the equipment

List of Spare Parts

No	Component Name	Specification and model	Quantity	Unit	Note
1	deep groove ball bearing	6206-zz	4	pc	
2	Suspended bearing	UCFB206	2	pc	
3	Emergency button	NP2-BS542	1	pc	rotate for resetting
4	Normally-closed contact	NP2-BE102	2	pc	
5	indicator	ND16-22DS/2 AC/DC	1	pc	24V white
6	Fusible core	RT28N-32X 1P 2A	2	pc	
7	Master switch	FYP-402 four-direction	1	pc	Automatic reset
8	Three-position rotatory switch	LA155A	2	pc	
9	Illuminated button	NP2-BW3361 24V LED	1	pc	
10	Flashing beep	ND16-22FS AC/DC 24V	1	pc	Red DC 24V
11	Repeater	CR-2C-DC24V(X) DC 24V	2	set	Two pairs of contacts
12	Proximity switch	IME 12-08NPSZW2S IME12	1	pc	

List of special tools

No	Tool name	Quantity	Unit	Note
1	Hexagon wrench	1	set	
2	Adjustable wrench	1	pc	6mm ~ 32mm
3	Slotted screwdriver small	1	pc	3*75mm
4	Cross screwdriver large	1	pc	5*150mm